

**HEADER**

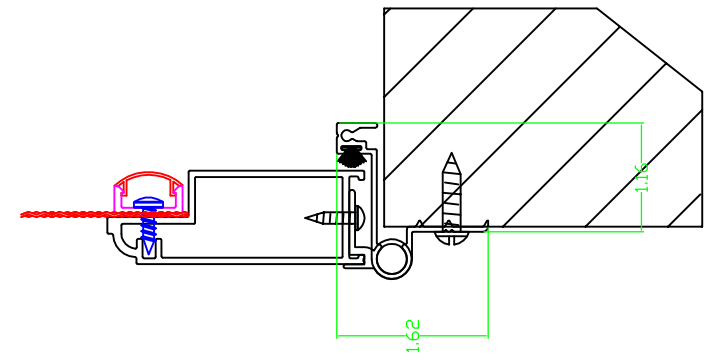

**HINGE SIDE Z-BAR**

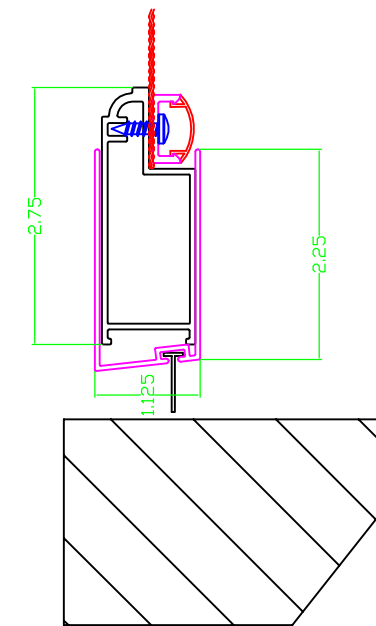

**BOTTOM EXPANDER**

**SYSTEM NOTES:**

1. FRAME & PANEL CONSTRUCTION: HEAVY DUTY EXTRUDED ALUMINUM SCREEN FRAME WITH Z-BAR.
2. FRAME CONTAINS SEVERAL CONCEALED HINGES DEPENDING ON THE SIZE WITH SELF-LUBRICATING BRASS BUSHINGS INTEGRALLY LOCKED INTO THE FRAME EXTRUSION.
3. FABRIC CONSTRUCTION: SCREEN FABRIC IS MADE UP OF T-304 STAINLESS STEEL, WITH .028" WIRE ARRANGED 12 STRANDS PER INCH.
4. THE SCREEN FABRIC IS ATTACHED TO THE EXTRUDED ALUMINUM PANEL FRAME WITH THE SCREEN RETAINER SYSTEM.
5. ALUMINUM EXTRUDED FRAME AND WIRE MESH ARE POWDER COATED WITH A STANDARD COLORS.

UNLESS OTHERWISE NOTED, DIMENSIONS ARE IN INCHES

<p><i>TOLERANCES EXCEPT AS NOTED reference</i></p>	CUST. NAME:	PART NUMBER: VARIOUS	
	PART NAME:	HEAVY DUTY SCREEN DOOR	MATERIAL: ALUMINUM WITH STAINLESS STEEL
	TREATMENT:	POWDER COATED	SHEET # <u>1</u> OF <u>1</u> SHEETS
<p>.X ± .060 .XX ± .030 .XXX ± .015</p>			DRAWN BY : GMP
			<p>Checked BY: DATE: 1-12-2010</p>
<p>ANGULAR ± 1°</p>	<p>This information is considered proprietary to Centurion Security Screen Co, LTD, and shall not be given to a third party without express permission</p>		<p>THIRD ANGLE PROJECTION SCALE: NTS</p>